

▪ **Swing check valves** ▪ 640 AA ▪ PN 10-40 ▪ DN 50-250

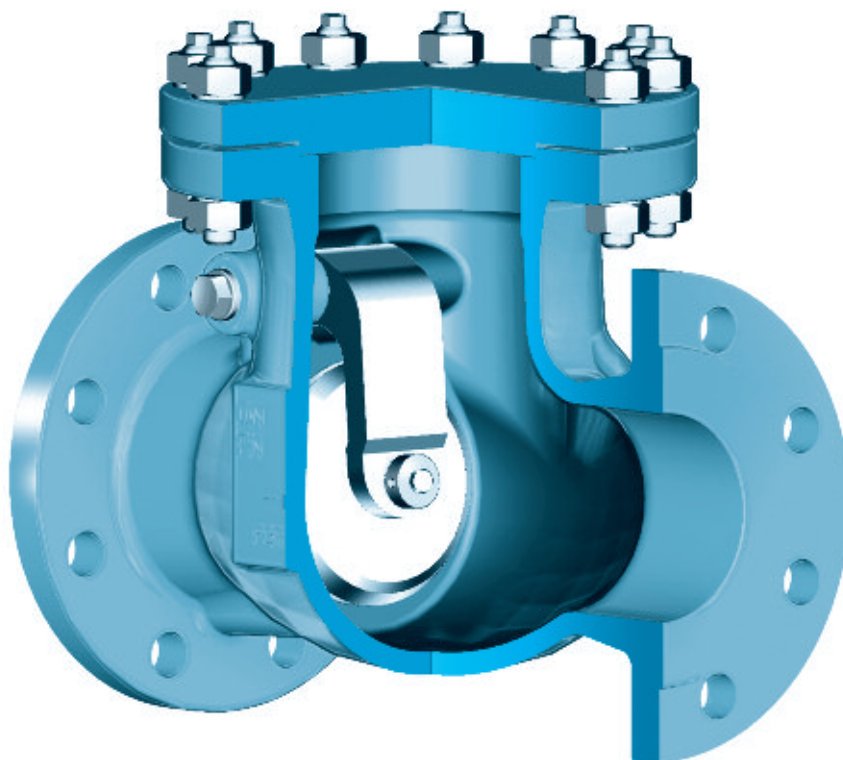

Range of application

Admissible operating pressure [bar] at design temperature [°C] ¹⁾

Material	PN	-10	20	120	150	200	250	300	350	400	450
1.0619	10-16	16	16	16	15	14	13	11	10	8	5
	25	25	25	25	23	22	20	17	16	13	8
	40	40	40	40	37	35	32	28	24	21	10

1) Operating temperature = design temperature minus temperature surcharge acc. to DIN regulations.

▪ **Swing check valves** ▪ 640 AA ▪ PN 10-40 ▪ DN 50-250

Standard features

- Body cast steel

Pressure and temperature ratings

- Pressure rating up to 40 bar
- Temperature rating up to +450° C

Materials

- 1.0619

Further materials on request

Media

Depending on the material swing check valves are suitable for water, gas, oil and other non aggressive media

Fields of application

Chemical industries, power plants, ship building and other

Design Highlights

- Hard faced integral body seat with 13 % or 17 % Cr-steel
- Shut-off disc with curved journal within the lever
- The lever rests on the hinge pin by means of a separate bearing bush

Benefits

- Extremely resistant to wear
- To improve movability and therefore to improve the adjustment of the disc to the body seat
- Improved resistance to wear by means of proper material selection

▪ **Swing check valves** ▪ 640 AA ▪ PN 10-40 ▪ DN 50-250

Flange-Version

EE-Version

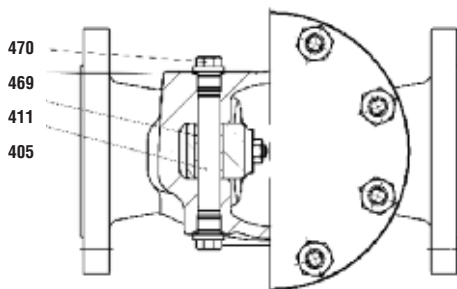
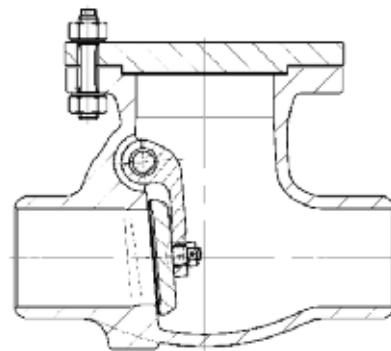
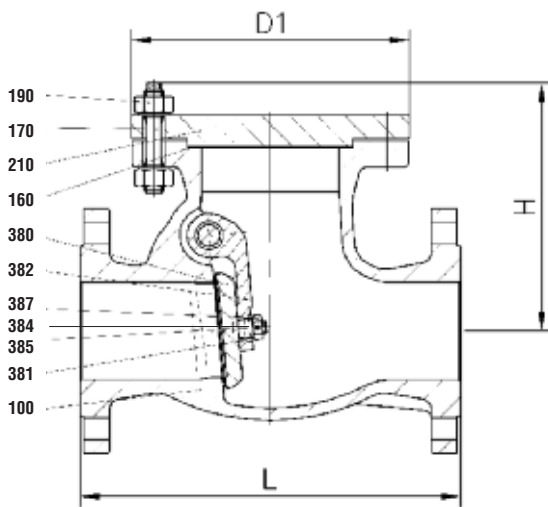

■ **Swing check valves** ■ **640 AA** ■ **PN 10-40** ■ **DN 50-250**

Materials

Pos.	Component	1.0619 (11)
100	Body welded on with	1.0619 Cr17
160	▶ Gasket	Graphite ²⁾
170	Screw bolt	1.1181
190	Hexagonal nut	1.1181
210	Cover	1.0460
380	▶ Disc welded on with	1.4021 ¹⁾
382	▶ Hinge	1.0425
384	▶ Bushing	1.4006
385	▶ Pint	1.4370
387	▶ Hexagonal nut	1.1181
405	▶ Hinge pin	1.4021
411	▶ Guide bushing	1.4006
469	▶ Gasket	2.4066
470	Screw plug	1.7709
	▶ Spare parts	

Further materials on request.
 1) ≥ DN 125 1.0460 welded on with Cr17
 2) ≥ DN 150 grooved with graphite layer

Dimensions/mm

DN	L	H	D
50	230	165	172
65	290	185	212
80	310	210	227
100	350	225	257
125	400	255	292
150	480	310	327
200	600	370	412
250	730	435	462

Weights/kg and Kvs-values

DN	Flange	BW-Ends	Kvs (m ³ /h)
50	19	13	
65	31	23	170
80	36	27	256
100	52	39	400
125	70	53	625
150	104	82	900
200	146	108	1600
250	289	249	2500