

## Downstream pressure reducer/stabilizer in stainless steel Mod. VRCD FF

The CSA valve Mod. VRCD FF reduces and stabilizes the downstream pressure regardless of flow rate and upstream pressure variations. It can be used for water, air and fluids in general with a maximum working pressure of 64 bar.



### Technical features and benefits

- Entirely manufactured in stainless steel machined from a solid bar.
- Upstream and downstream pressure balanced, to stabilize the downstream pressure to a preset (and adjustable) value regardless of upstream pressure variations without creating unwanted upsurges.
- Innovative self cleaning piston technology, pat. pending, to improve performances reducing maintenance operations.
- Mobile block composed of stainless obtained by CNC to ensure the maximum accuracy and sliding precision, this is to avoid friction and unexpected leakage.
- Upstream/downstream pressure outlets for gauges.
- Cavitation proof thanks to the design and special gaskets, high pressure ratio are allowed without the risk of cavitation.
- Epoxy powder applied using FBT technology.

### Applications

- Water distribution systems for high pressure ratio.
- Buildings and civil installations whenever stainless steel is required or advised for project aspects.
- Demineralized water and bottling plants.
- Industry and cooling systems.
- Fuel and other fluids in general with the use of special gaskets (please contact CSA).

## Operating principle

The operating principle of VRCD-FF, upstream pressure balanced, is based on a piston sliding into two rings of different diameters. These rings form a watertight chamber, also known as the compensation chamber, which is necessary for the accuracy and stability of the valve.



### Valve normally open

Without any pressure the VRCD-FF is a normally open valve, where the piston is kept pushed down by the force of the spring located in the cover.

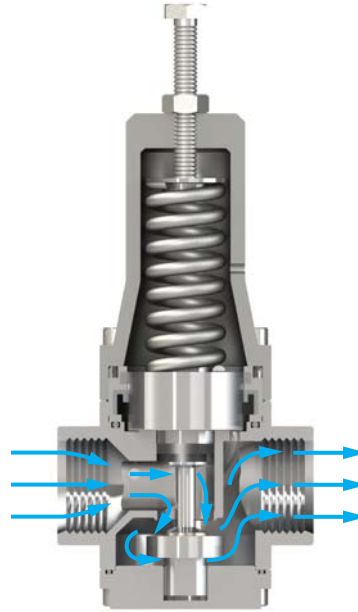

### Valve fully open

During working conditions, should the downstream pressure drop below the valve's set point obtained by the compression of the spring, the VRCD-FF will open completely allowing the full passage.

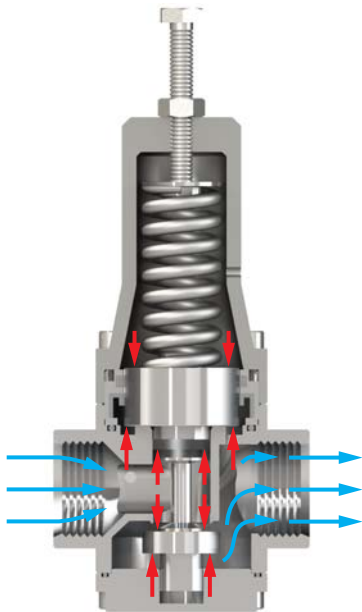

### Valve modulating

Should the downstream pressure rise above the valve's set point the resultant of the force obtained by the downstream pressure, acting on the mobile block and the compensation chamber against the spring pushing downwards, will raise the obturator producing the required head loss to stabilize the downstream pressure.

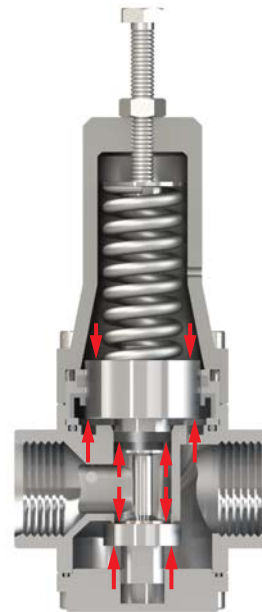

### Valve fully closed (static conditions)

In case of downstream pressure rise above the valve's set point, should the modulating phase of the valve not be enough to stabilize the pressure, the valve will close maintaining the required downstream pressure value even in static conditions.

## Technical data

DN in	1/2	1	1 1/2	2
Kv (m <sup>3</sup> /h)/bar	2,9	7,2	10,8	21

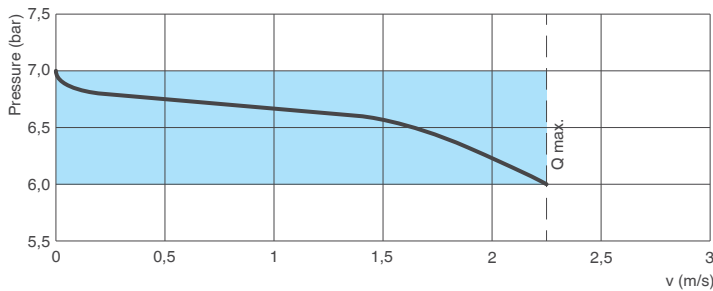
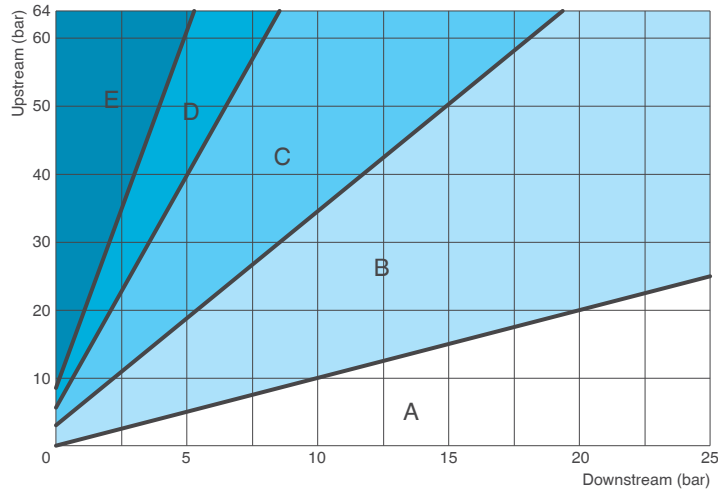

## Working conditions

Treated water with a maximum temperature of 70°C (120°C on request).

Upstream pressure (inlet): maximum 64 bar.

Higher downstream pressure values on request.

DN [in]	1/2	1	1 1/2	2
Available spring pressure range bar	2-10	1,5-8	1,5-7	1,5-6
	2-20	2-20	2-15	5-12

DN in	A mm	B mm	C mm	D mm	Weight Kg
1/2	53	--	108	25	1,0
1	90	CH 41	170	45	2,1
1 1/2	110	CH 55	205	50	2,8
2	152	CH 70	290	60	5,9

## Head loss coefficient

Kv coefficient representing the flow rate which is flowing through the valve fully open producing a head loss of 1 bar.

## Cavitation chart

The cavitation phenomenon is very important during the proper valve sizing process since it may lead to substantial damages, in addition to vibration and noise. The cavitation chart has to be used to determine whether the intersection of the line, connecting upstream and downstream pressure conditions, lies within one of the 5 zones to be identified as follows:

- A: Out of the possible working conditions;
- B: Recommended working conditions;
- C: Incipient cavitation;
- D: Damage cavitation;
- E: Choked and unpredictable conditions, please consult CSA for further assistance.

## Reduced pressure falloff

The plot is showing the reduced pressure falloff that occurs through the valve when the flow increases. The area depicted in blue includes the recommended working range and maximum velocity.

## Standard

Designed in compliance with EN-1074/4.

Threaded connections according to BS standard.

Changes and variations on the thread available on request.

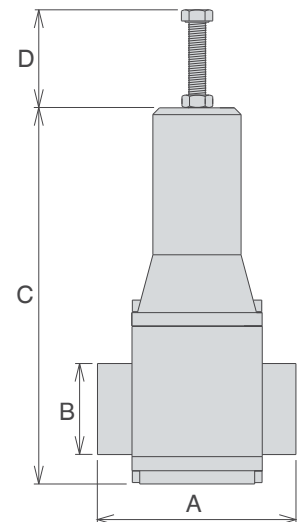

## Technical details

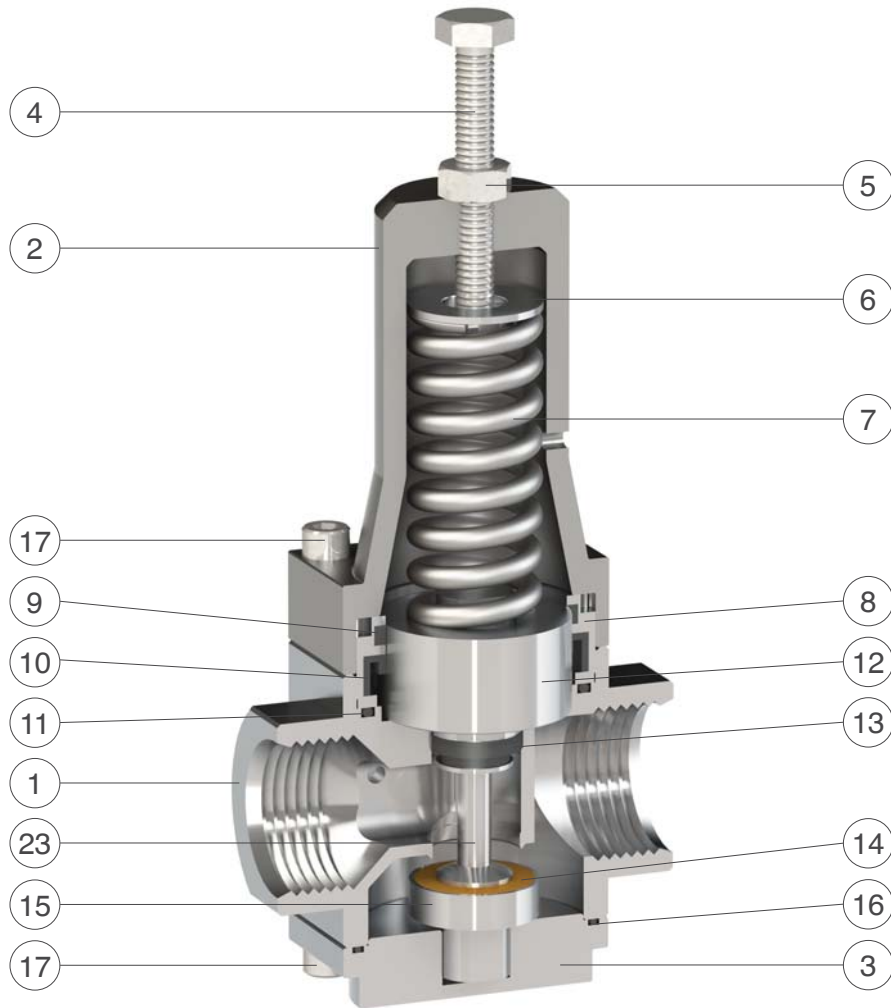

N.	Component	Material	Standard
1	Body	stainless steel	AISI 303/316
2	Cap	Ni-plated aluminium/s.s.	AISI 303/316
3	Driving tap	stainless steel	AISI 303/316
4	Driving screw	stainless steel	AISI 304/316
5	Nut	stainless steel	AISI 304/316
6	Spring guide	stainless steel	AISI 303/316
7	Spring	stainless/spring steel	Si-Cr
8	Main bush	stainless steel	AISI 303/316
9	Sliding ring	PTFE	
10	Upper gasket	NBR/EPDM	
11	O-ring	NBR/EPDM	
12	Piston	stainless steel	AISI 303/316
13	Lower gasket	NBR	
14	Plane gasket	NBR/polyurethane	
15	Obturator guide	stainless steel	AISI 303/316
16	Tap o-ring	NBR/EPDM	
17	Screw	stainless steel	AISI 304/316